

VSI

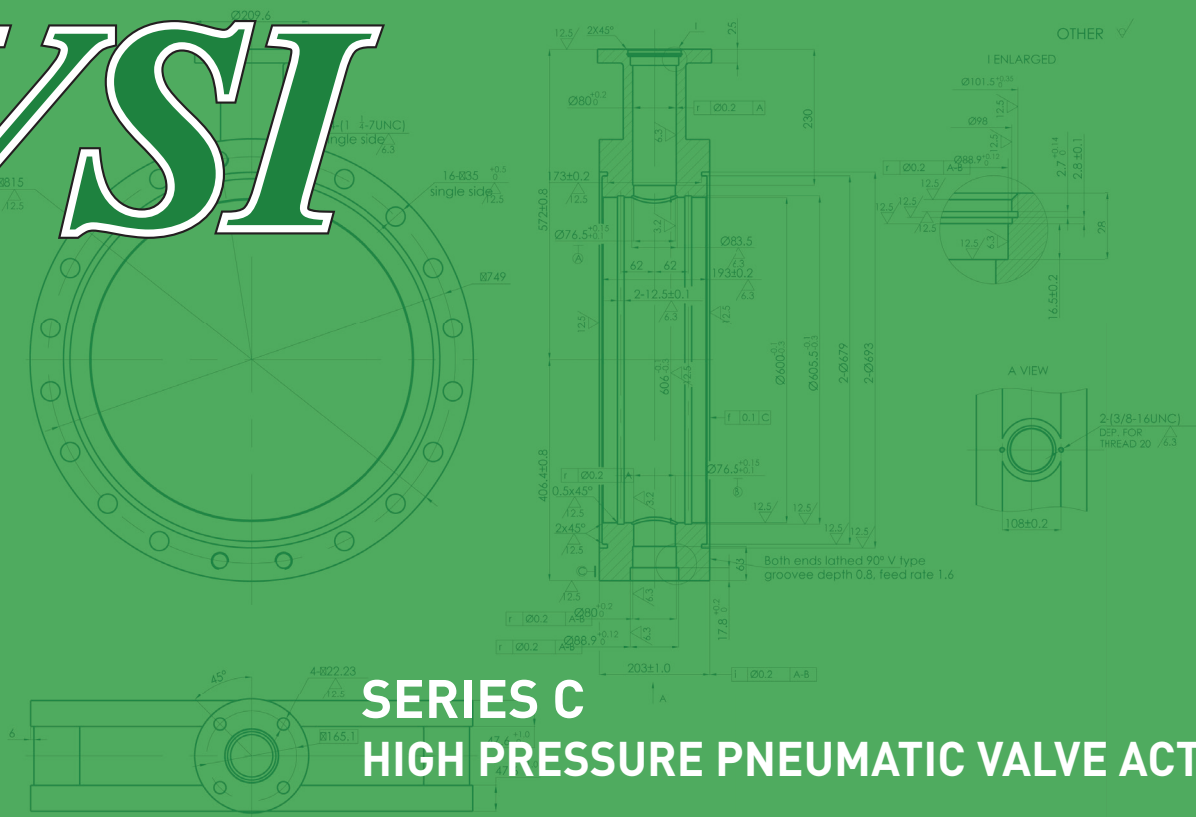

SERIES C HIGH PRESSURE PNEUMATIC VALVE ACTUATORS

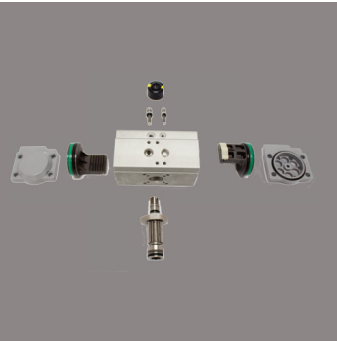

GENERAL WORKING CONDITIONS

Torque Range	47,272 inlbs (Double Acting) 22,534 inlbs (Spring Return)
Air Supply	Minimum 40psi, Maximum 130psi
Temperature	32F to 176F Lubricated Air -4F to 176F Dry Air -58F to 300F with Special Considerations
Operating Media	Compressed air, lubrication not necessary. If lubricated, use non-detergent oil or NBR compatible oil

DOUBLE ACTING OPERATION

CCW

Air is supplied to Port A forcing the pistons away from each other (towards ends), rotating the drive pinion counter-clockwise and exhausting air out of Port B

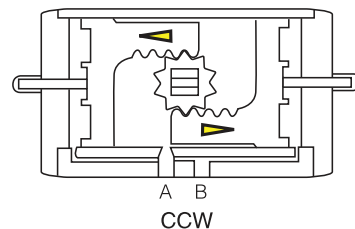

CW

Air is supplied to Port B forcing the pistons toward each other (towards center), rotating the drive pinion clockwise and exhausting air out of Port A

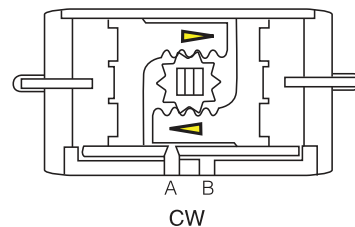

PAGE 2

SPRING RETURN OPERATION

FAIL CCW

Air is supplied to Port A forcing the pistons away from each other (towards ends), rotating the drive pinion counter-clockwise, compressing the springs and exhausting air out of Port B

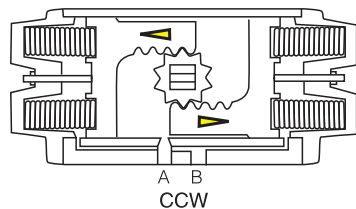

FAIL CW

Air failure (loss of pressure) allows the compressed springs to force the pistons toward each other (towards center), rotating the drive pinion clockwise and exhausting air out of Port A

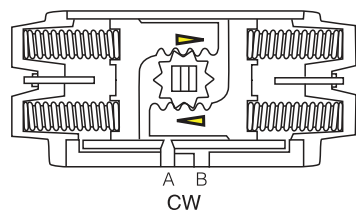

PARTS AND MATERIALS

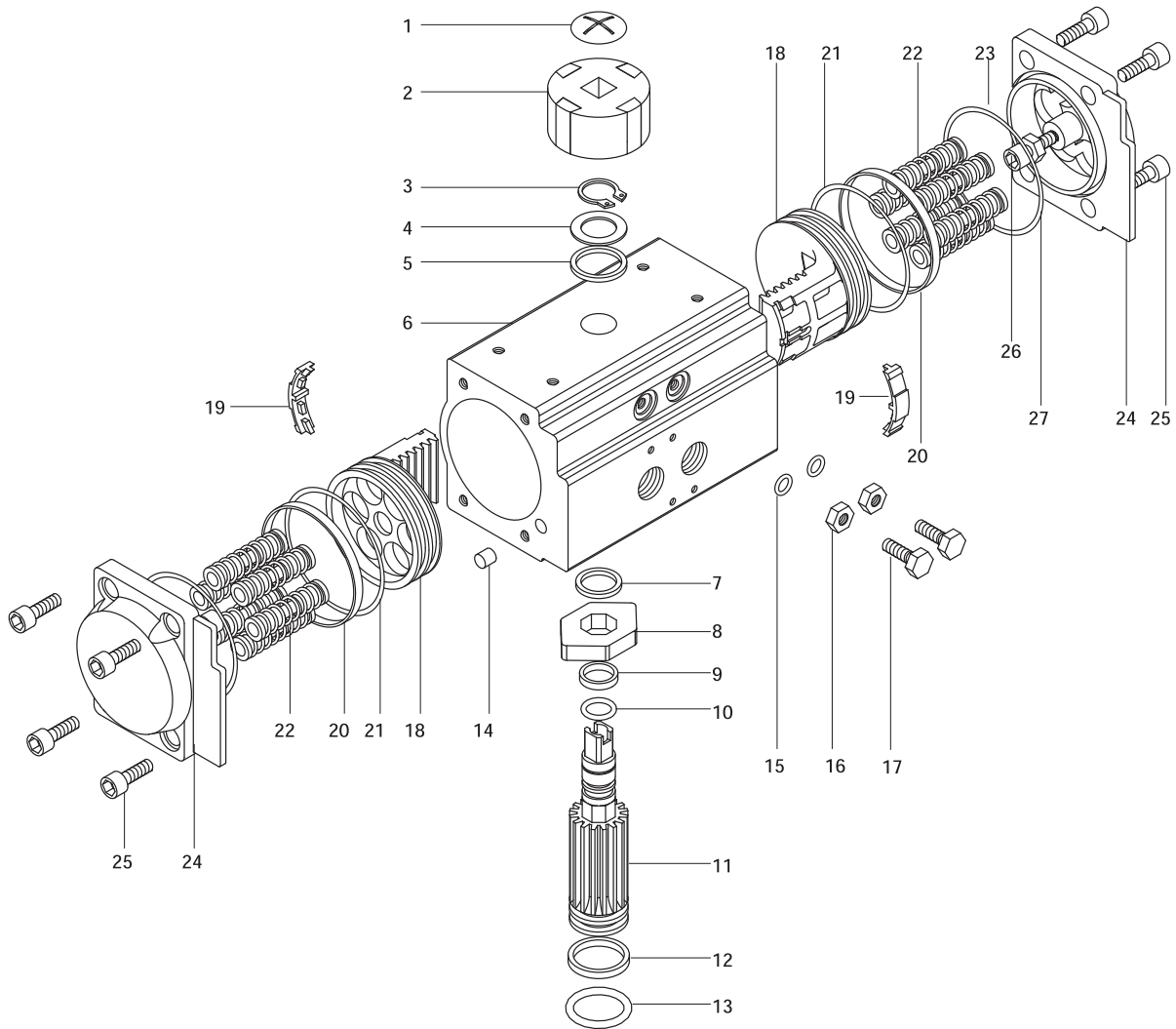

No.	Description	Qty.	Standard Material
1	Indicator Screw	1	Plastic
2	Indicator	1	Plastic
3	Snap Ring	1	Stainless Steel
4	Thrust Washer	1	Stainless Steel
5	Outside Washer	1	Plastic
6	Body	1	Aluminum Alloy (6005-T5)
7	Inside Washer	1	Plastic
8	Cam	1	Alloy Steel
9	Top O-Ring	1	NBR
10	Top Bearing	1	Plastic
11	Pinion	1	Alloy Steel (45#)
12	Bottom O-Ring	1	NBR
13	Bottom Bearing	1	Plastics
14	Plug	2	NBR

No.	Description	Qty.	Standard Material
15	Adjustment Screw O-Ring	2	NBR
16	Adjustment Screw Nut	2	Stainless Steel
17	Adjustment Screw	2	Stainless Steel
18	Piston	2	Cast Aluminum (101A)
19	Piston Guide	2	Plastic
20	Piston Bearing	2	Plastic
21	Piston O-Ring	2	NBR
22	Spring	0~12	Spring Steel
23	End Cap O-Ring	2	NBR
24	End Cap	2	Cast Aluminum (ADC12)
25	Cap Screw	8	Stainless Steel
26	Stop Screw	2	Stainless Steel
27	Stop Screw Nut	2	Stainless Steel

AIR CONSUMPTION AND WEIGHTS

AIR CONSUMPTION (cubic in.)					
Model Number	Opening	Closing	Model Number	Opening	Closing
C-45	4.88	6.71	C-160	225.79	195.28
C-63	12.81	14.04	C-190	360.04	329.53
C-83	26.24	28.68	C-210	457.68	457.68
C-92	39.06	44.55	C-240	671.26	549.21
C-105	57.97	53.70	C-270	1037.40	854.33
C-125	97.64	85.43	C-300	1452.37	1812.41
C-140	152.56	134.25			

WEIGHT TABLE (lbs)					
Model Number	DA	SR	Model Number	DA	SR
C-45	2.20	2.43	C-160	44.09	52.91
C-63	4.41	4.63	C-190	68.37	77.16
C-83	6.83	7.94	C-210	103.62	121.25
C-92	10.14	11.46	C-240	147.74	176.37
C-105	14.99	15.24	C-270	213.85	260.15
C-125	19.68	22.27	C-300	242.51	286.60
C-140	28.66	33.07			

C-45 DIMENSIONS

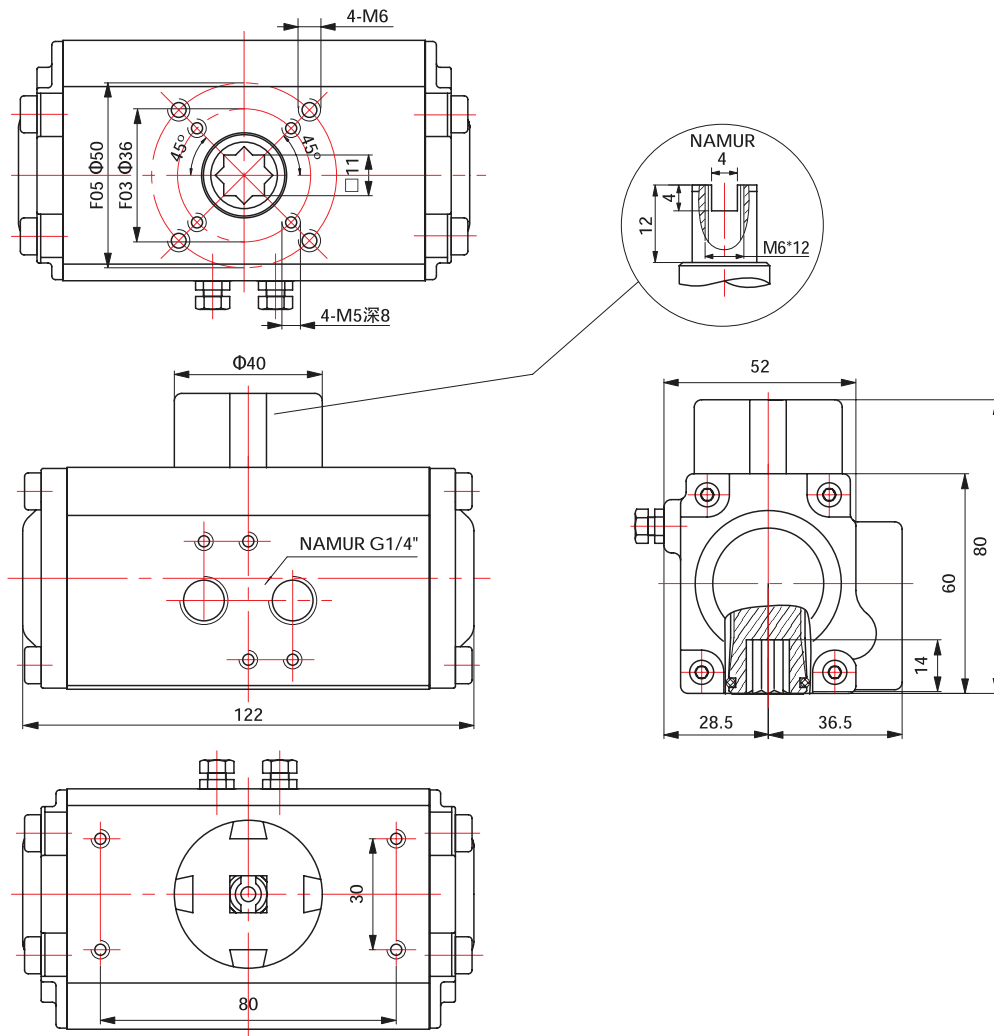

PAGE 4

C-63 TO C-140 DIMENSIONS

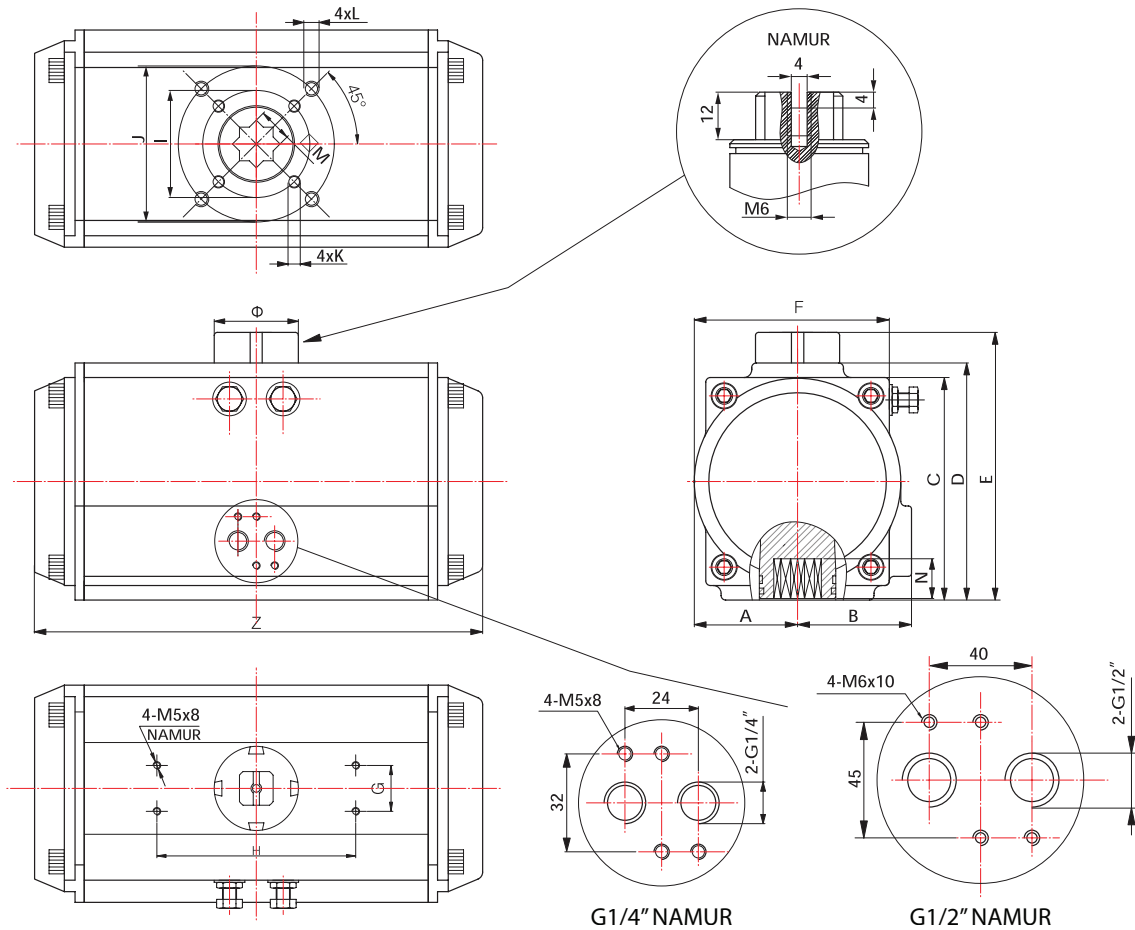

DIMENSIONAL TABLE mm/in

MODEL	A	B	C	D	E	F	G	H	I	J	K	L	M	N	Z	Ø	AIR CONNECTION
C-63	36 1.42	47 1.85	81 3.19	87.5 3.44	107.5 4.23	72 2.83	30 1.18	80 3.15	Ø50	Ø70	M6x10	M8x13	14 0.55	18 0.71	168 6.61	Ø40	NAMUR G1/4"
C-83	46 1.81	57 2.24	98.5 3.88	108.7 4.28	128.7 5.07	92 3.62	30 1.18	80 3.15	Ø50	Ø70	M6x10	M8x13	17 0.67	21 0.83	204 8.03	Ø40	NAMUR G1/4"
C-92	50 1.97	58.5 2.30	111 4.37	116.5 4.59	136.5 5.37	98 3.86	30 1.18	80 3.15	Ø50	Ø70	M6x10	M8x13	17 0.67	21 0.83	262 10.31	Ø40	NAMUR G1/4"
C-105	57.5 2.26	64 2.52	122.5 4.82	133 5.24	153 6.02	109.5 4.31	30 1.18	80 3.15	Ø70	Ø102	M8x13	M10x16	22 0.87	26 1.02	268 10.55	Ø40	NAMUR G1/4"
C-125	67.5 2.66	74.5 2.93	145.5 5.73	155 6.10	175 6.89	127.5 5.02	30 1.18	80 3.15	Ø70	Ø102	M8x13	M10x16	22 0.87	26 1.02	301 11.85	Ø55	NAMUR G1/4"
C-140	75 2.95	77 3.03	161 6.34	172 6.77	192 7.56	137.5 5.41	30 1.18	80 3.15	Ø102	Ø125	M10x16	M12x20	27 1.06	31 1.22	390 15.35	Ø55	NAMUR G1/4"

C-160 TO C-300 DIMENSIONS

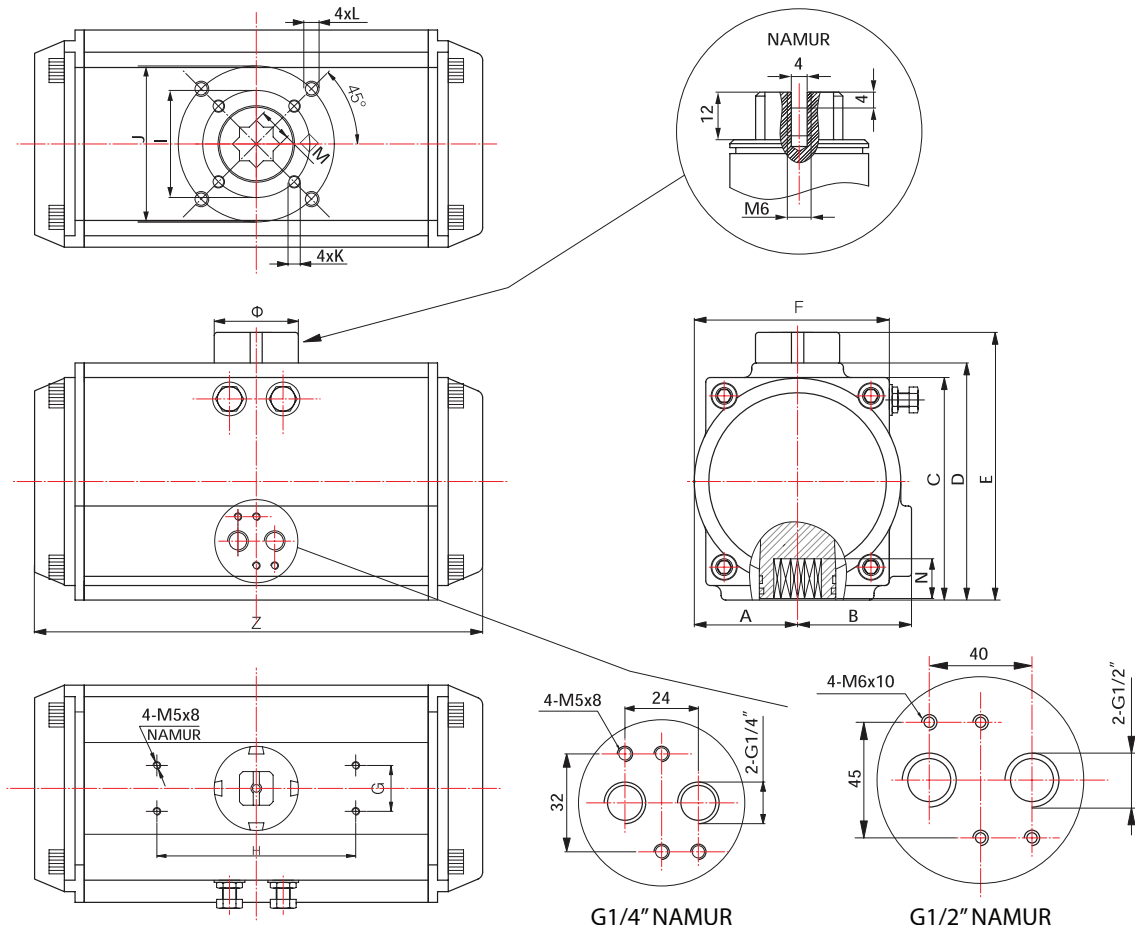

PAGE 6

DIMENSIONAL TABLE mm/in

MODEL	A	B	C	D	E	F	G	H	I	J	K	L	M	N	Z	Ø	AIR CONNECTION
C-160	87	87	184	197	217	158	30	80	Ø102	Ø125	M10x16	M12x20	27	31	458	Ø55	NAMUR G1/4"
	3.43	3.43	7.24	7.76	8.54	6.22	1.18	3.15					1.06	1.22	18.03		
C-190	103	103	213	230	260	189	30	130	-	Ø140	-	M16x25	36	40	525	Ø80	NAMUR G1/4"
	4.06	4.06	8.39	9.06	10.24	7.44	1.18	5.12					1.42	1.57	20.67		
C-210	113	113	235.5	255	285	210	30	130	-	Ø140	-	M16x25	36	40	532	Ø80	NAMUR G1/4"
	4.45	4.45	9.27	10.04	11.22	8.27	1.18	5.12					1.42	1.57	20.94		
C-240	130	130	264.5	289	319	245	30	130	-	Ø165	-	M20x25	46	50	602	Ø80	NAMUR G1/4"
	5.12	5.12	10.41	11.38	12.56	9.65	1.18	5.12					1.81	1.97	23.70		
C-270	147	147	299	326	356	273	30	130	-	Ø165	-	M20x25	46	50	722	Ø80	NAMUR G1/2"
	5.79	5.79	11.77	12.83	14.02	10.75	1.18	5.12					1.81	1.97	28.43		
C-300	162	162	348	348	378	324	30	130	Ø165	Ø215	M20x25	M20x25	46	60	742	Ø80	NAMUR G1/2"
	6.38	6.38	13.70	13.70	14.88	12.76	1.18	5.12					1.81	2.36	29.21		

OUTPUT TORQUES FOR SPRING RETURN MODELS

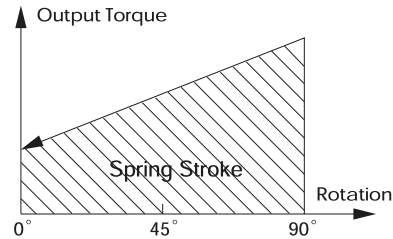
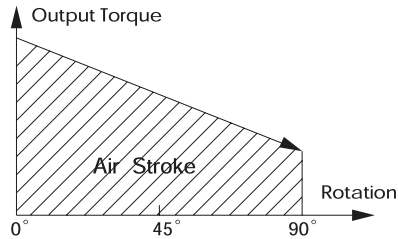

Model	Springs per Side	AIR DRIVEN OUTPUT TORQUE (in/lb)								SPRING OUTPUT TORQUE (in/lb)	
		Air Pressure (PSI)									
		58		73		87		102		90°	0°
		0° Start	90° End	0° Start	90° End	0° Start	90° End	0° Start	90° End	90° Start	0° End
C-SR63	3	185	147	250	212	-	-	-	-	111	73
	4	161	110	226	175	290	239	355	304	148	96
	5	136	73	202	138	266	202	330	266	185	121
	6	-	-	177	101	242	165	306	229	221	145
C-SR83	3	387	311	526	449	-	-	-	-	244	168
	4	331	228	470	367	609	506	748	645	326	224
	5	274	147	413	286	552	425	691	564	407	280
	6	-	-	358	205	497	344	635	482	489	336
C-SR92	3	551	434	751	634	-	-	-	-	365	248
	4	468	312	668	512	868	712	1068	912	487	330
	5	386	190	586	390	786	590	985	789	608	413
	6	-	-	503	269	703	469	902	668	730	496
C-SR105	3	834	648	1127	940	-	-	-	-	523	336
	4	722	474	1015	766	1307	1059	1600	1352	697	448
	5	610	296	903	589	1196	882	1489	1174	871	560
	6	-	-	791	420	1084	713	1376	1005	1045	672
C-SR125	3	1221	947	1664	1390	-	-	-	-	832	558
	4	1036	664	1478	1106	1921	1558	2372	2000	1106	743
	5	850	389	1292	832	1735	1275	2186	1717	1390	929
	6	-	-	1106	558	1558	1000	2000	1443	1664	1106
C-SR140	3	2115	1655	2876	2416	-	-	-	-	1372	912
	4	1814	1204	2576	1956	3328	2717	4089	3469	1823	1213
	5	1505	743	2266	1496	3018	2257	3779	3009	2283	1522
	6	-	-	1956	1044	2717	1797	3469	2558	2744	1823



OUTPUT TORQUES FOR SPRING RETURN MODELS

Model	Springs per Side	AIR DRIVEN OUTPUT TORQUE (in/lb)								SPRING OUTPUT TORQUE (in/lb)	
		Air Pressure (PSI)								90° Start	0° End
		58		73		87		102			
0° Start	90° End	0° Start	90° End	0° Start	90° End	0° Start	90° End	90° Start	0° End		
C-SR160	3	3231	2496	4408	3673					2213	1487
	4	2735	1761	3912	2098	5089	4116	6266	5293	2947	1974
	5	2239	1018	3416	2195	4594	3372	5771	4549	3691	2469
	6			2921	1460	4098	2638	5275	3815	4425	2965
C-SR190	3	5408	4248	7293	6134					3284	2124
	4	4700	3151	6585	5036	8470	6921	10347	8806	4381	2832
	5	3992	2062	5877	3947	7762	5824	9647	7709	5470	3540
	6			5169	2850	7054	4735	8939	6620	6567	4248
C-SR210	3	6496	5381	8851	7736					4036	2921
	4	5523	4036	7877	6390	10231	8745	12586	11099	5381	3894
	5	4549	2691	6904	5045	9258	7399	11612	9754	6727	4868
	6			5930	3700	8284	6054	10639	8408	8072	5841
C-SR240	3	9267	7736	12674	11143					5886	4355
	4	7815	5780	11214	9178	14621	12586	18029	15993	7842	5806
	5	6355	3815	9762	7222	13170	10630	16569	14037	9807	7266
	6			8311	5257	11710	8665	15117	12064	11771	8718
C-SR270	3	14754	12356	19932	17533					8346	5948
	4	12780	9568	17958	14745	23136	19932	28314	25101	11134	7921
	5	10798	6789	15976	11966	21153	17144	26322	22313	13913	9904
	6			14002	9178	19180	14365	24348	19534	16701	11878
C-SR300	4	15524	10320	22277	17073					15020	10338
	5	12657	6151	19410	12904	26163	19658	32916	26411	18781	12922
	6			16533	8727	23286	15480	30039	22233	22534	15507

PAGE 8

1 - "Spring Output Torque" is under "Loss of Air Pressure" & "Actuator Output Torque" is under spring force condition
 2 - Normally Closed Valve: Actuator at 0 degrees, valve is closed; actuator at 90 degrees, valve is open.
 3 - Normally Open Valve: Actuator at 0 degrees, valve is open; actuator at 90 degrees, valve is closed.
 Note: The above actuator output torque data has factored in the loss due to friction and passing of the force. The actual output torque of the actuator will be no less than the above data.



OUTPUT TORQUES FOR DOUBLE ACTING MODELS

MODEL	INPUT AIR PRESSURE (psi)				
	58	73	80	87	102
C-DA45	89	106	115	124	150
C-DA63	257	319	354	389	451
C-DA83	558	690	761	832	974
C-DA92	797	1000	1097	1195	1398
C-DA105	1168	1460	1611	1752	2045
C-DA125	1770	2222	2443	2664	3107
C-DA140	3027	3779	4160	4540	5293
C-DA160	4709	5886	6470	7063	8240
C-DA190	7532	9417	10355	11302	13188
C-DA210	9417	11771	12949	14126	16480
C-DA240	13621	17029	18728	20428	23835
C-DA270	20702	25880	28464	31057	36235
C-DA300	27012	33766	37147	40519	47272

WARRANTY

This limited warranty applies in the United States to products manufactured by VSI, LLC. VSI, LLC. warrants the product purchased from it or its authorized reseller to be free from defects in material and workmanship under normal use during the two year warranty period from the date of its purchase. Other products not manufactured by VSI, LLC. which are provided as part of an assembly may carry additional warranties from that manufacturer or supplier.

During the warranty period, VSI, LLC. will repair or replace defective parts of the product, or, at VSI, LLC. sole option, issue a credit for the original purchase price of the product. Repaired or replaced product will be warranted hereunder only for the remaining portion of the original warranty period. All exchanged products under this Limited Warranty will become the property of VSI, LLC. A proper Return Material Authorization (RMA) number will have to be obtained for all products to be returned under this Limited Warranty. Any claim under this Limited Warranty must include a description of the problem encountered and any relevant information that may assist VSI, LLC. in the replication or resolution of the problem.

This Limited Warranty is transferable during its term to the end user of the product. Any transfer shall not extend or alter the terms of this Limited Warranty.

This Limited Warranty extends only to products purchased from VSI, LLC. or its authorized reseller and does not extend to any product that has been damaged or rendered defective as a result of (a) modification, repair, alteration or improper installation by any person other than VSI, LLC. or its authorized representative; (b) unreasonable or improper use or storage, use beyond rated conditions, operation other than per VSI, LLC. or the manufacturer's instructions, or being otherwise subjected to improper maintenance, negligence or accident; or (c) any use of the product after purchaser has knowledge of any defect in the product.

The warranties provided above are in lieu of and exclude all other warranties, statutory, express or implied, including without limitation any warranty or merchantability or fitness for a particular purpose. VSI, LLC. expressly disclaims all warranties not stated in this limited warranty. Any implied warranties that may be imposed by law are limited to the terms of this limited warranty.

VSI, LLC. warranty liability shall not exceed the original purchase price of the defective product. VSI, LLC. is not liable for any damages caused by the product or other products or the failure of the product or other products to perform, including any lost profits, lost savings, incidental or consequential damages. VSI, LLC. is not responsible for charges resulting from the removal and/or replacement of the product. VSI, LLC. is not liable for any claims made by third parties or by the purchaser for a third party. This limitation applies whether damages are sought, or a claim is made, under the Limited Warranty or as a tort claim, product liability claim, contract claim, or any other claim. This limitation cannot be waived by any person. This limitation of liability will be effective even if VSI, LLC. or its authorized representative has been advised by the purchaser of the possibility of such damages.

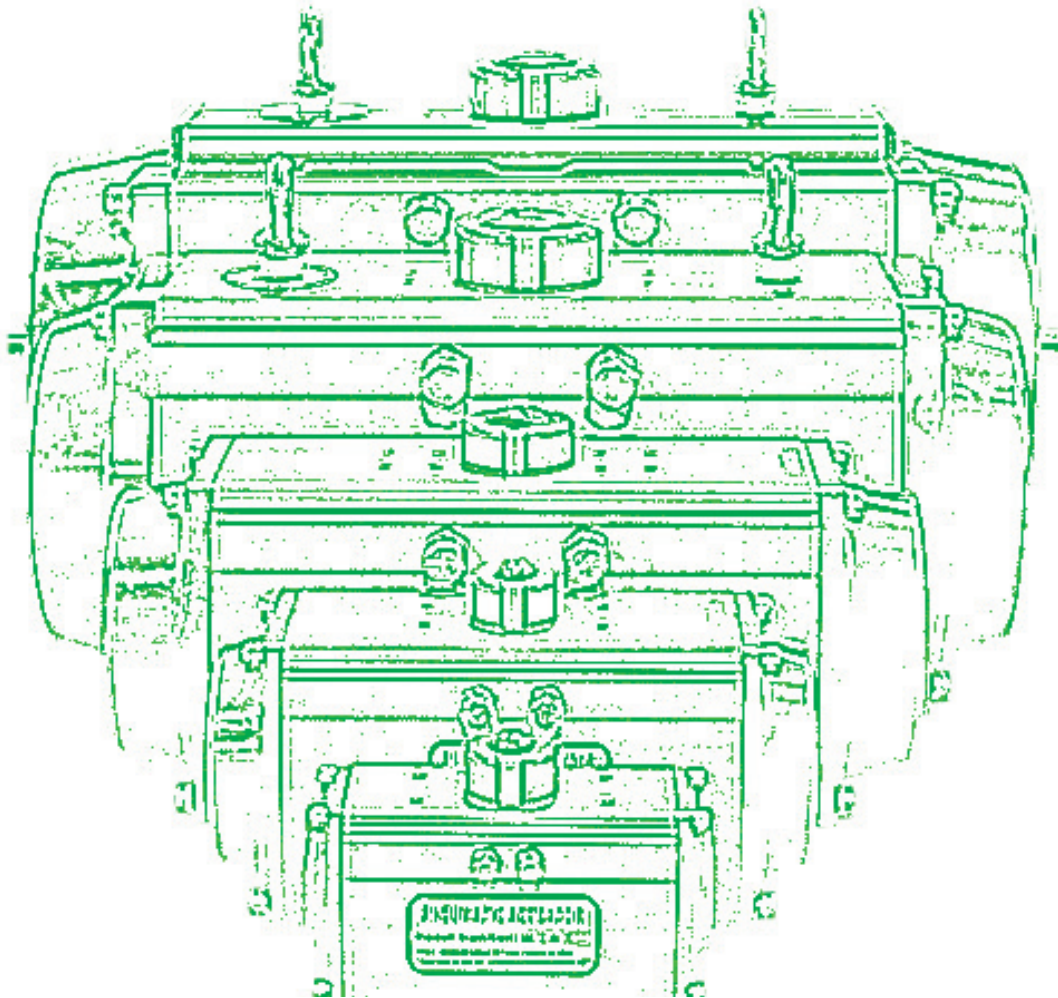

Valve Solutions, Inc
tel: 1 (770) 740 0800
fax: 1 (770) 740 8777
email: sales@valvesolutions.com

VSI

www.ValveSolutions.com

As part of a process of on-going product development, VSI reserves the right to amend or change specifications without prior notice. Published data may be subject to change. For the latest version, visit our website at www.valvesolutions.com